

ST. VRAIN SANITATION DISTRICT STANDARD MANHOLE

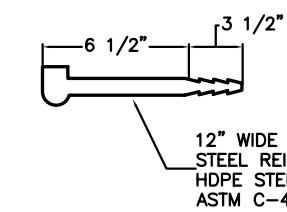
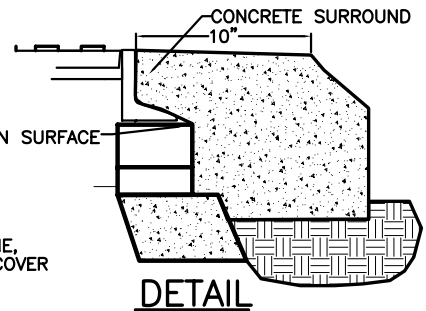
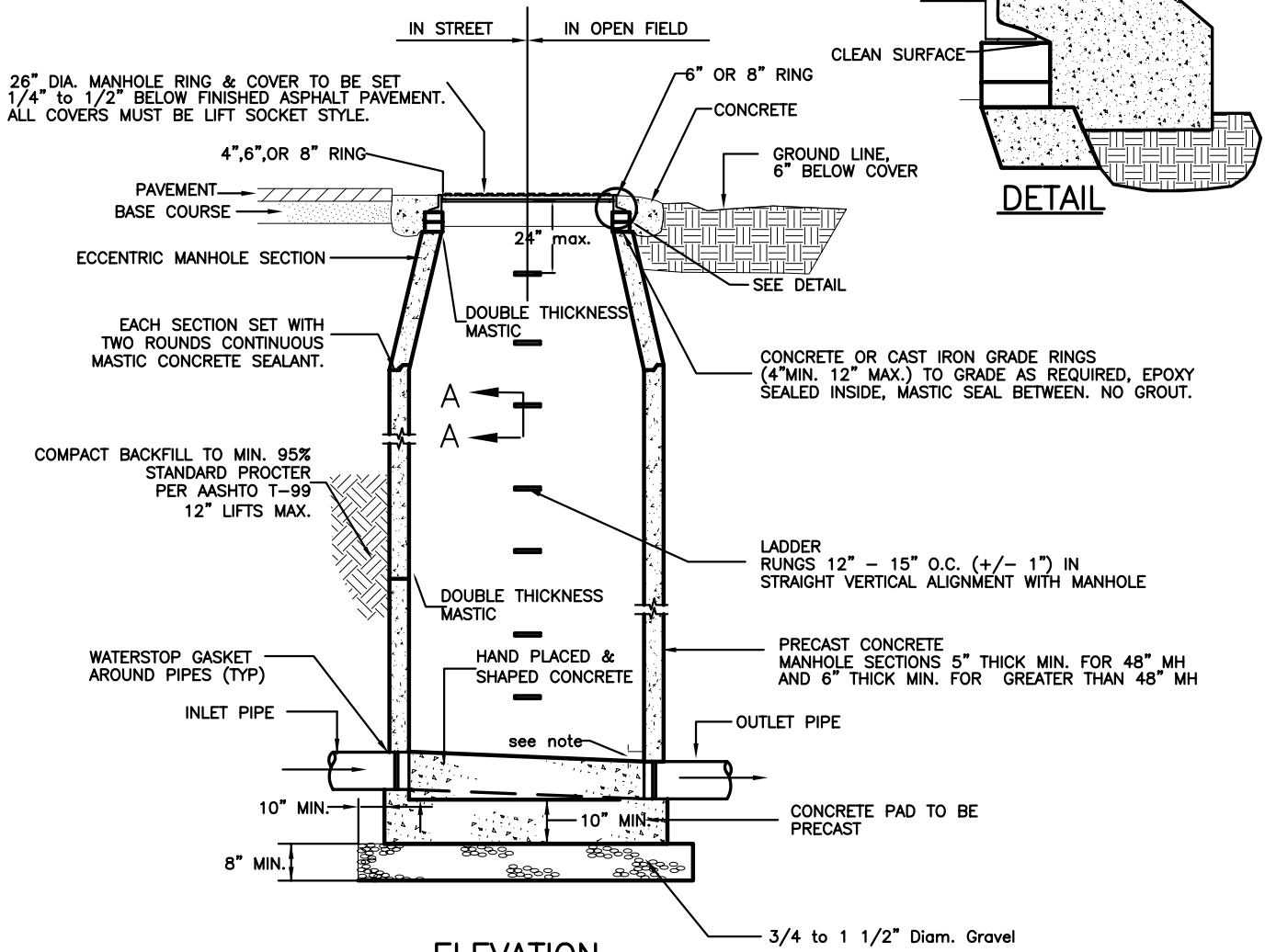

SECTION A-A

ELEVATION

| PIPE SIZE | MIN. MH DIAM. |
|------------------|---------------|
| 15" > pipe | 48" |
| 18" < pipe < 27" | 60" |
| 30" < pipe | 72" |

| MIN. DROP THRU MANHOLE: | |
|----------------------------|-------------------|
| FLOW DIRECTION CHANGE(FDC) | MIN. DROP |
| 0 DEG < FDC < 30 DEG. | 0.1' |
| 90 DEG < FDC < 30 DEG | 0.2' |
| 0 DEG | SLOPE OF PIPE RUN |
| 90 DEG < | NOT ALLOWED |

NOTE: MANHOLES SHALL BE SEALED WATERTIGHT. NO GROUT ALLOWED EXCEPT AT PIPE PENETRATIONS. GROUT CEMENT SHALL BE CALCIUM ALUMINATE ONLY. MANHOLE EXTERIORS SHALL BE DAMP-PROOFED.

Detail Number:

1

REVISED: 4/2010

ST. VRAIN SANITATION DISTRICT MANHOLE RING AND COVER

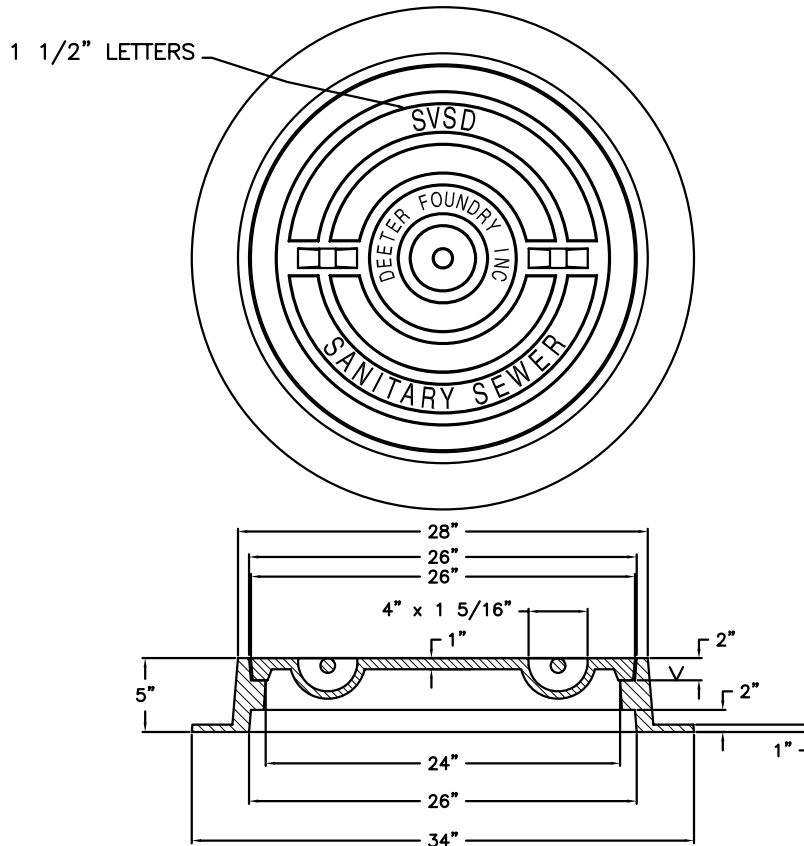

NOTES:

1. RING AND COVER SHALL BE IRON (AS MANUFACTURED FOR CURRENT AWWA STANDARD)
2. SANITARY SEWER MANHOLE COVERS SHALL BE NONPERFORATED WITH "SVSD SANITARY SEWER" FORGED ON THE TOP OF THE LID AS SHOWN ABOVE.
3. COVER SHALL BE BOLTED, WATER RESISTANT IF LOCATED IN 100 YEAR FLOOD PLAIN, BACK YARDS, OPEN SPACE AND/OR DITCHES.
4. ALL MANHOLES SHALL BE EQUIVALENT TO DEETER MODEL NUMBER 1156 OR D & L FOUNDRY MODEL A-1480.
5. MANHOLE LID AND RING SHALL BE FURNISHED WITH MACHINED HORIZONTAL BEARING SURFACES.

Detail Number:

2

REVISED: 4/2010

ST. VRAIN SANITATION DISTRICT BOLT-DOWN MANHOLE RING AND COVER

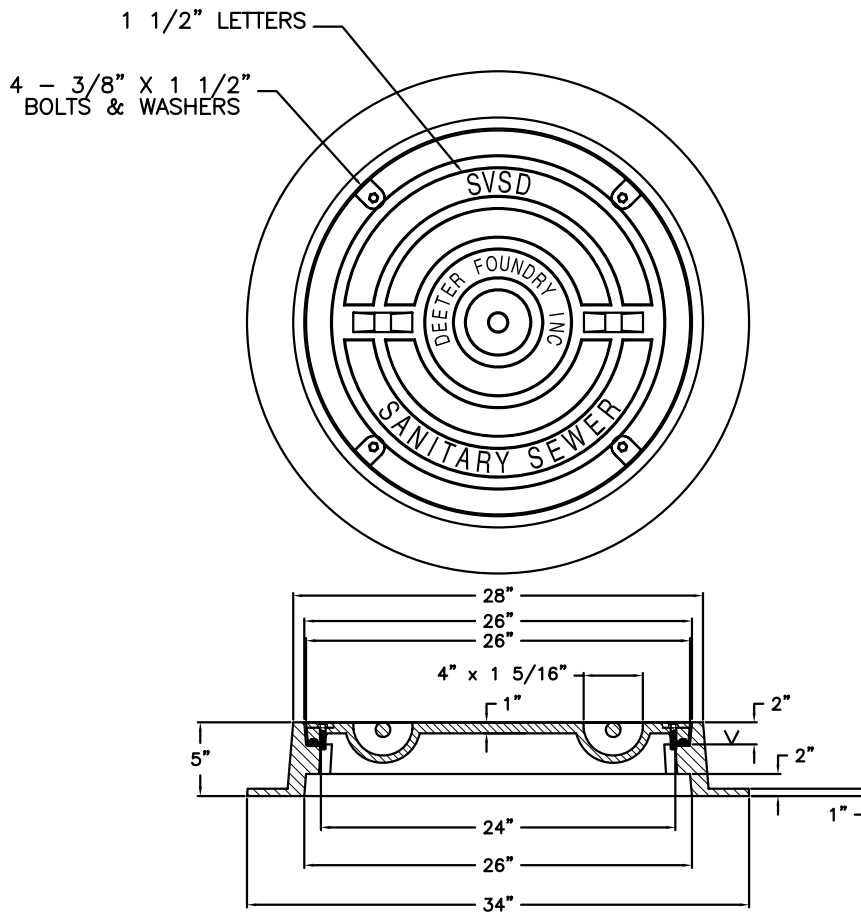

NOTES:

1. RING AND COVER SHALL BE IRON (AS MANUFACTURED FOR CURRENT AWWA STANDARD)
2. SANITARY SEWER MANHOLE COVERS SHALL BE NONPERFORATED WITH "SVSD SANITARY SEWER" FORGED ON THE TOP OF THE LID AS SHOWN ABOVE.
3. COVER SHALL BE BOLTED, WATER RESISTANT IF LOCATED IN 100 YEAR FLOOD PLAIN, BACK YARDS, OPEN SPACE AND/OR DITCHES.
4. ALL MANHOLES SHALL BE EQUIVALENT TO DEETER MODEL NUMBER 1156 OR D & L FOUNDRY MODEL A-1480.
5. MANHOLE LID AND RING SHALL BE FURNISHED WITH MACHINED HORIZONTAL BEARING SURFACES.
6. COVER IS BOLTED TO FRAME.
7. MANHOLE LID AND RING SHALL BE FURNISHED WITH GASKET.

Detail Number:

3

REVISED: 4/2010

ST. VRAIN SANITATION DISTRICT INSIDE DROP MANHOLE

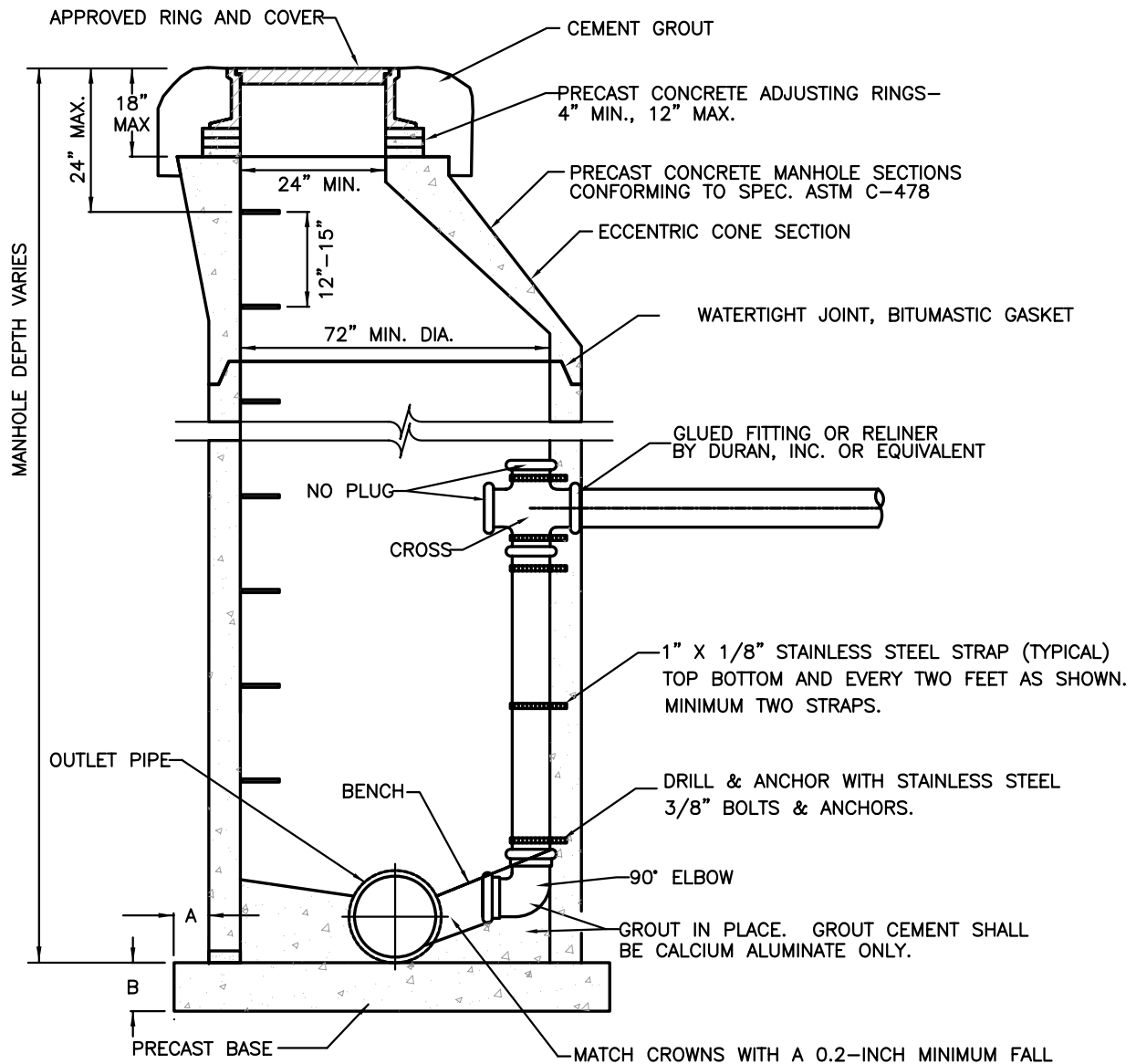

NOTE:
MINIMUM MANHOLE DIAMETER
SHALL BE 6 FEET

Detail Number:

4

REVISED: 4/2010

ST. VRAIN SANITATION DISTRICT MANHOLE BASE USED FOR TIE-IN SITUATIONS

FLOW DIRECTION CHANGE
90 DEGREES, MAXIMUM.

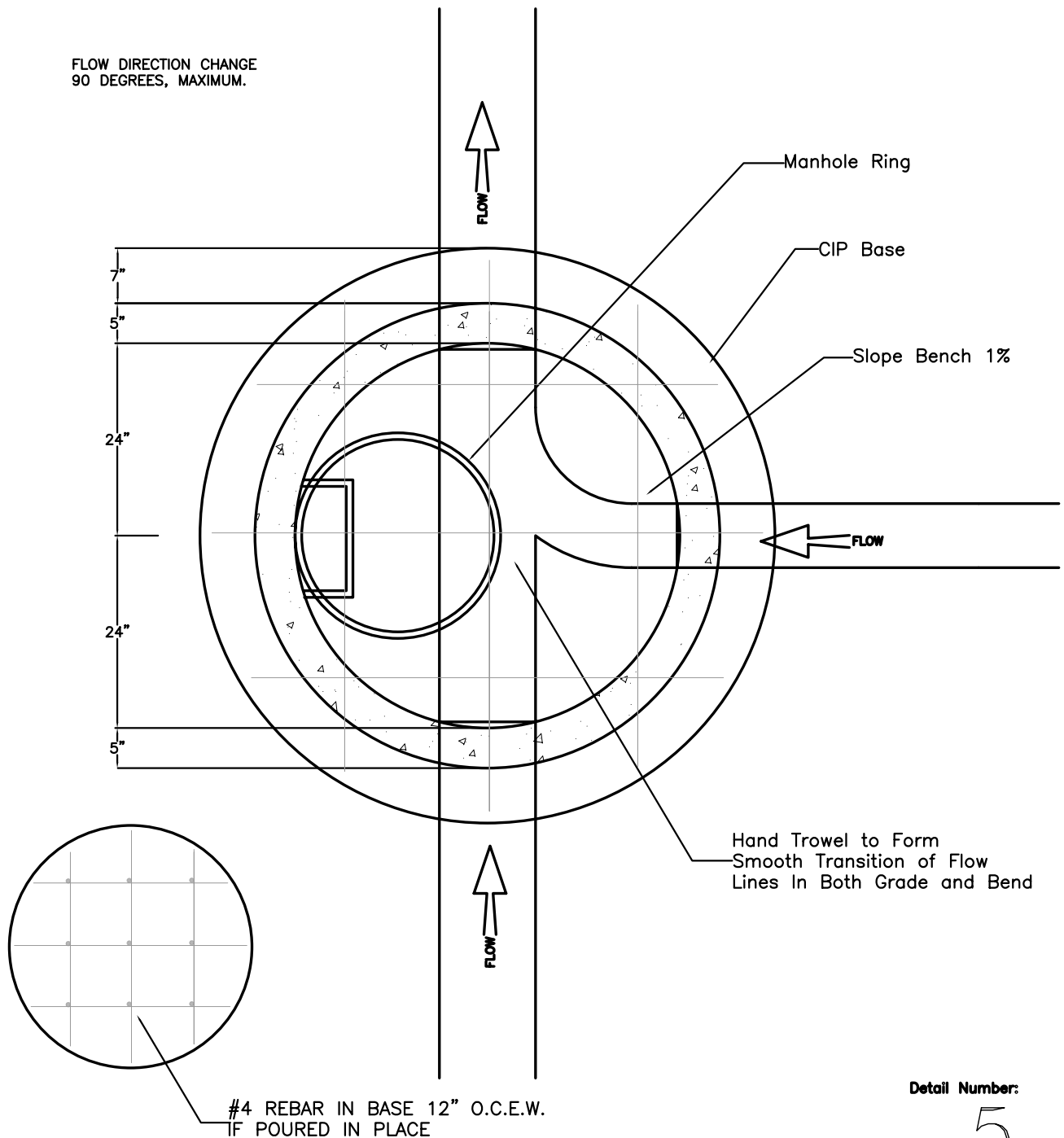

No Scale

REVISED: 4/2010

ST. VRAIN SANITATION DISTRICT UNDERDRAIN

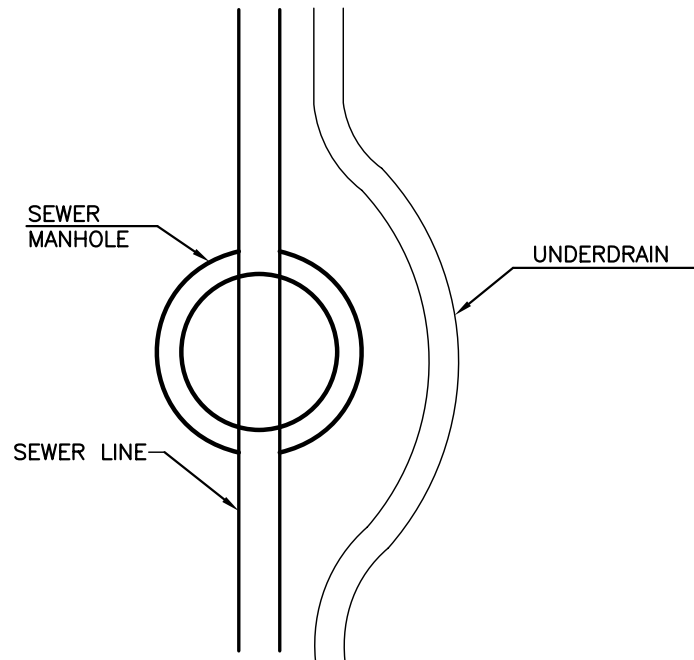

PLAN VIEW

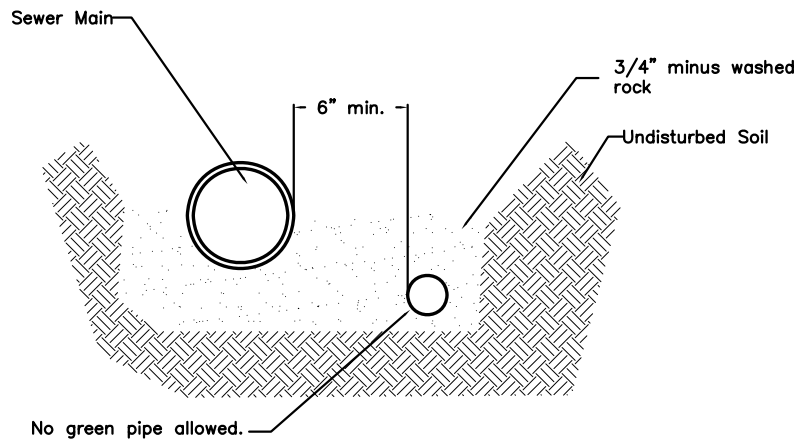

1. Distance Between Underdrain Invert And Sewer Invert To Be Equal To The Diameter Of The Drain Below The Sewer.
2. Maintain Positive Slope Of Underdrain To Daylight.
3. See Typical Trench Detail.
4. SVSD Shall Not Assume Ownership Of Underdrains And Will Not Be Responsible For Maintenance Of Same.

Detail Number:

6

REVISED: 4/2010

ST. VRAIN SANITATION DISTRICT ALL BASE SECTIONS

PIPE PENETRATIONS

NOTE:
THIS DETAIL IS APPLICABLE
FOR ALL PIPE PENETRATIONS
AT ALL MANHOLES

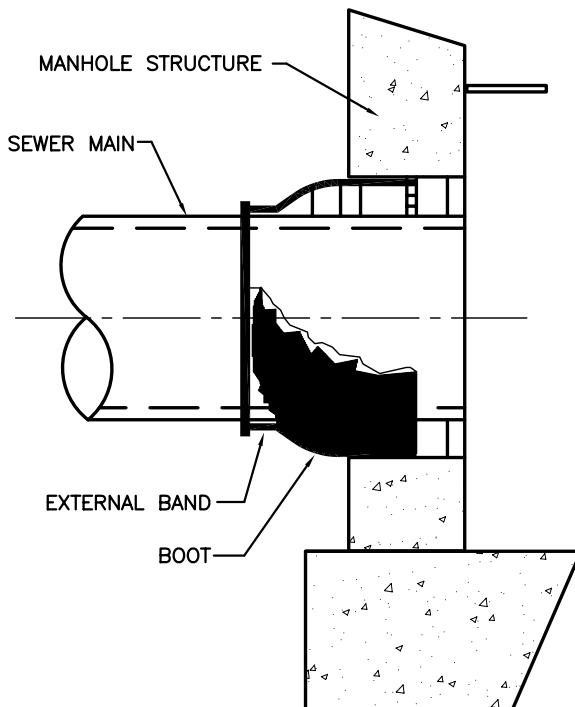
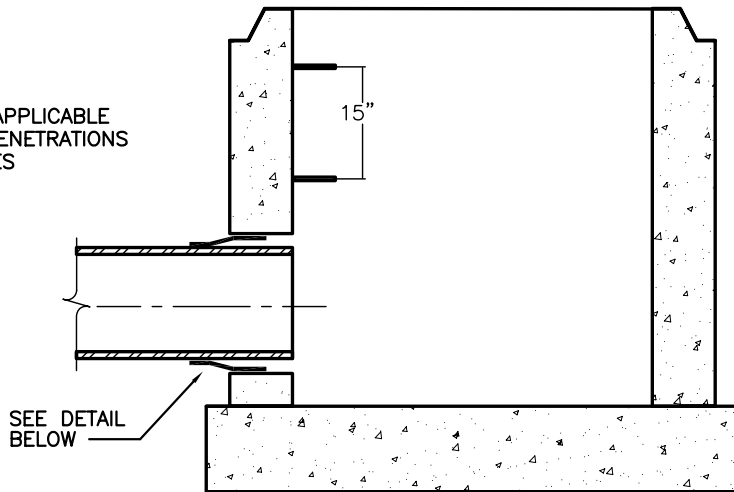

FLEXIBLE JOINT CONNECTION
ASTM C-443

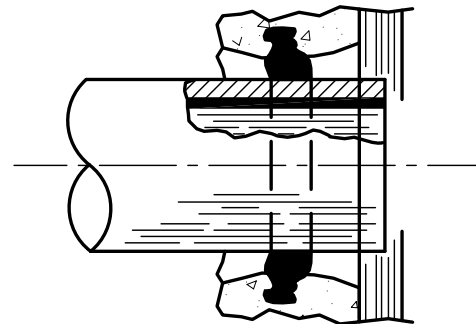

LOK GASKET DETAIL
ASTM C-443

** EITHER DETAIL IS ACCEPTABLE

Detail Number:

7

REVISED: 4/2010

ST. VRAIN SANITATION DISTRICT SEWER SERVICE CLEANOUT

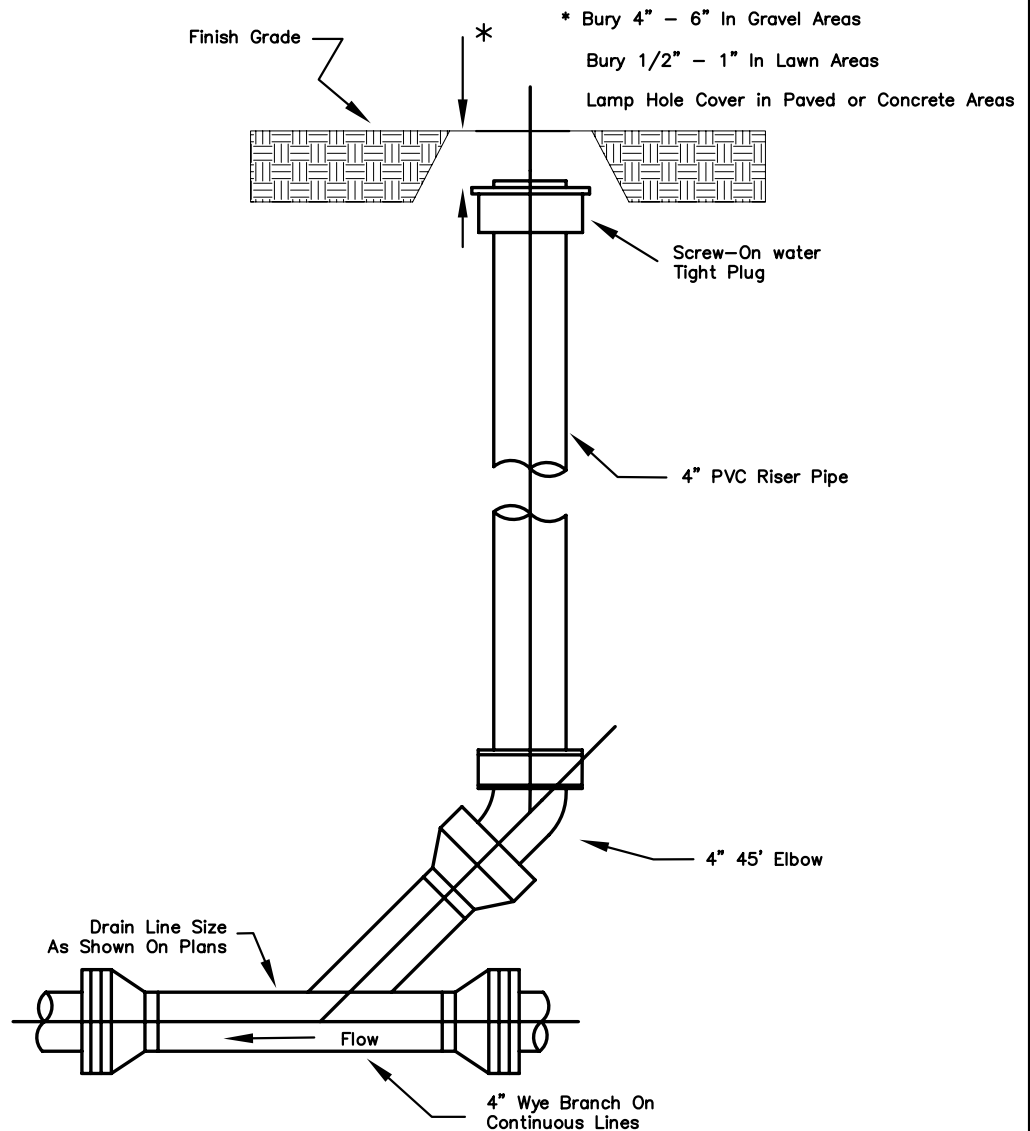

- NOTES:
1. Cleanout shall be constructed so that surface load will not be transfered to main.
 2. Service line cleanout may be installed approximately 5 feet outside the building foundation.
 3. A cleanout is required on all service lines every 100 feet, at every Y or after a combined total of 145 degrees of bend.

Detail Number:

8

REVISED: 4/2010

ST. VRAIN SANITATION DISTRICT TYPICAL SERVICE CONNECTION

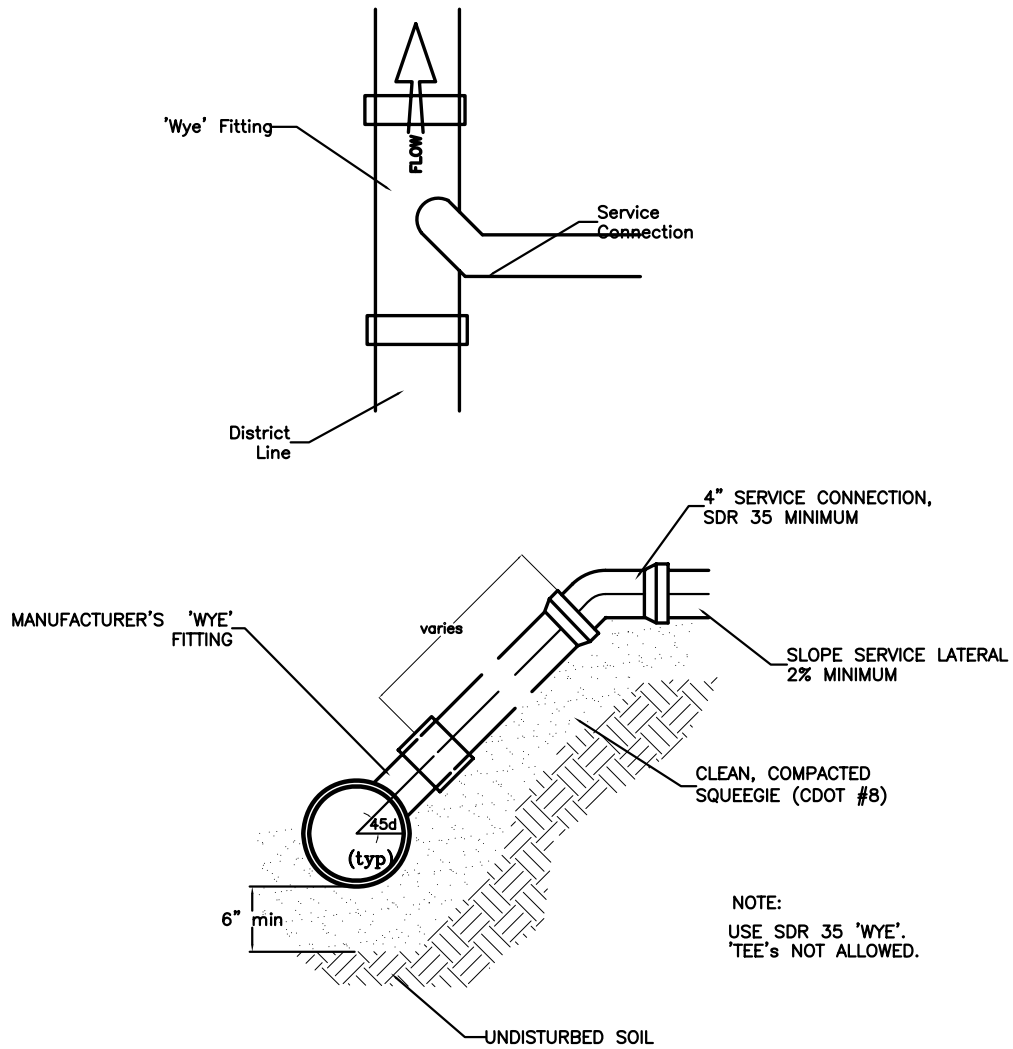

Detail Number:

9

REVISED: 4/2010

ST. VRAIN SANITATION DISTRICT SERVICE CONNECTION USING A TAPPING SADDLE

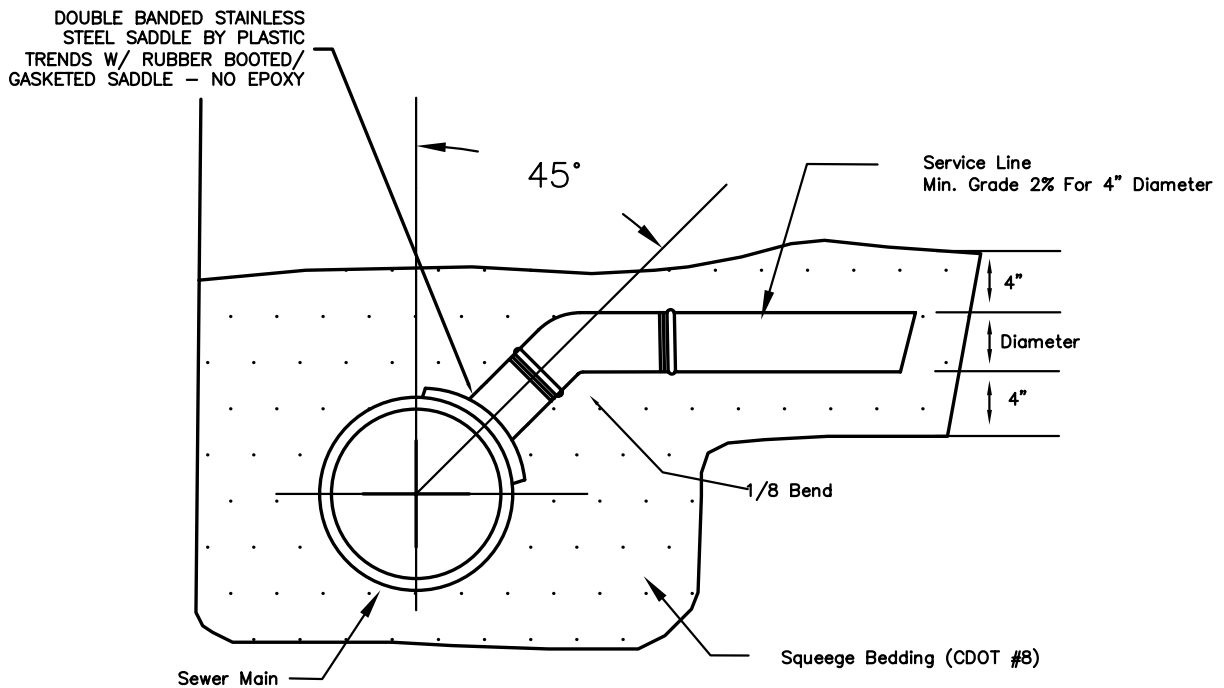

NOTES:

1. Approved Tapping Saddle To Be Used For New Services To Existing Mains Shall Be Tees. Pipe Penetrations Shall Be Mechanically Drilled.
2. Taphole Must Be Above The Springline.
3. 4" Sewer Services Shall Have A Minimum Slope Of 2.0%.
4. 6" Sewer Services Shall Have A Minimum Slope Of 1.0%.
5. Services Shall Not Be Closer Than 5 Ft. From Each Other On The Main.

Detail Number:

10

REVISED: 4/2010

ST. VRAIN SANITATION DISTRICT TYPICAL TRENCH FOR 8" TO 12" DIAMETER SANITARY SEWERS

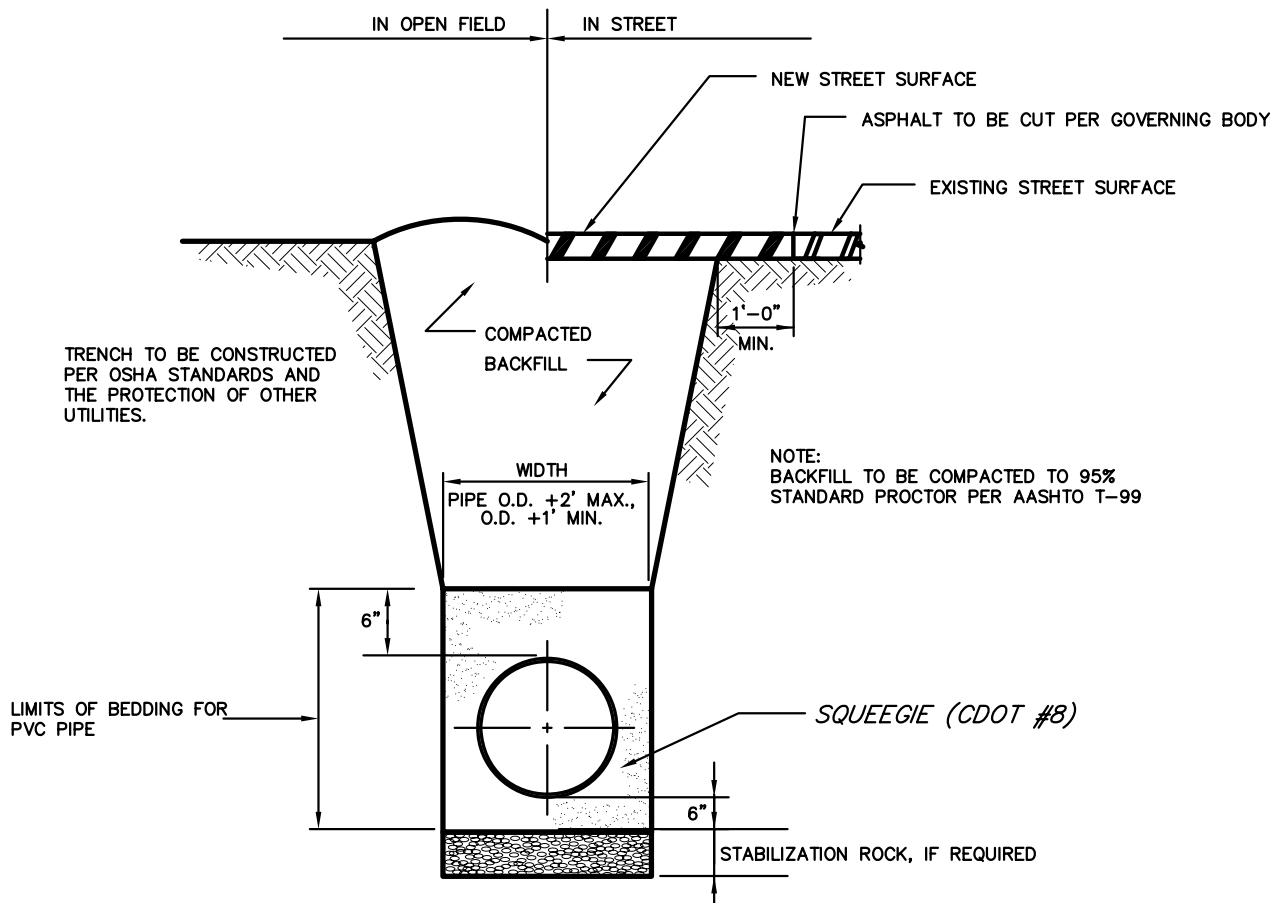

Notes:

1. Squeegee Sand Is Defined As CDOT No. 8, shown in Detail 21.
2. All Compaction Must Be By Mechanical Means. No Jetting or Flooding Of Trench.
3. Under No Circumstances Will Pipe Be Laid In A Proposed Fill Area Prior To It Being Completely Filled. The Fill Will Be Placed First To Proposed Grade And Compacted As Required. A Trench Then Will Be Excavated And The Pipe Installed In The Usual Manner.

Detail Number:

11

REVISED: 4/2010

ST. VRAIN SANITATION DISTRICT PIPE BEDDING FOR 15" AND LARGER SANITARY SEWERS

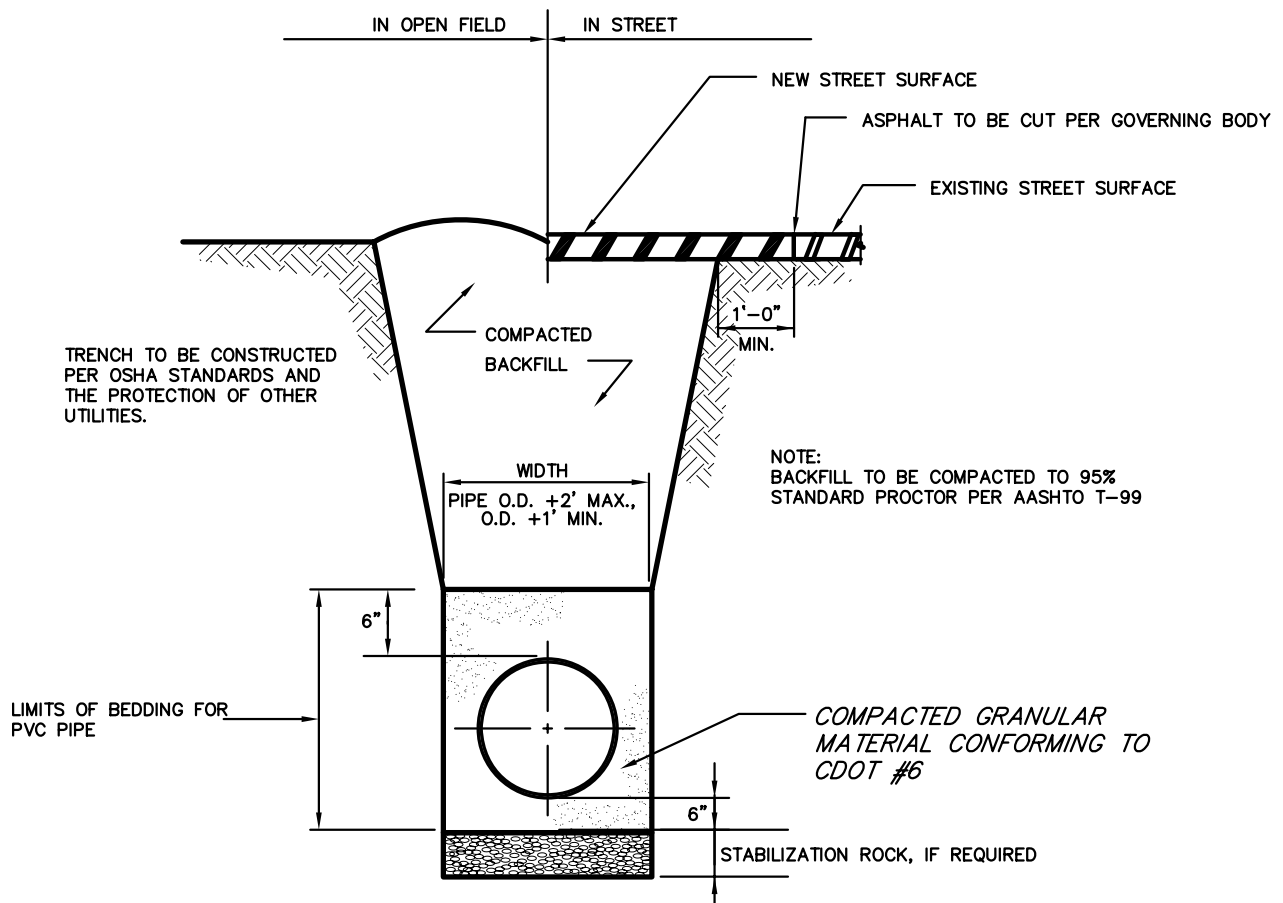

Notes:

1. All Compaction Must Be By Mechanical Means. No Jetting or Flooding Of Trench.
2. Under No Circumstances Will Pipe Be Laid In A Proposed Fill Area Prior To It Being Completely Filled. The Fill Will Be Placed First To Proposed Grade And Compacted As Required. A Trench Then Will Be Excavated And The Pipe Installed In The Usual Manner.

Detail Number:

12

REVISED: 4/2010

ST. VRAIN SANITATION DISTRICT UTILITY ENCASEMENT

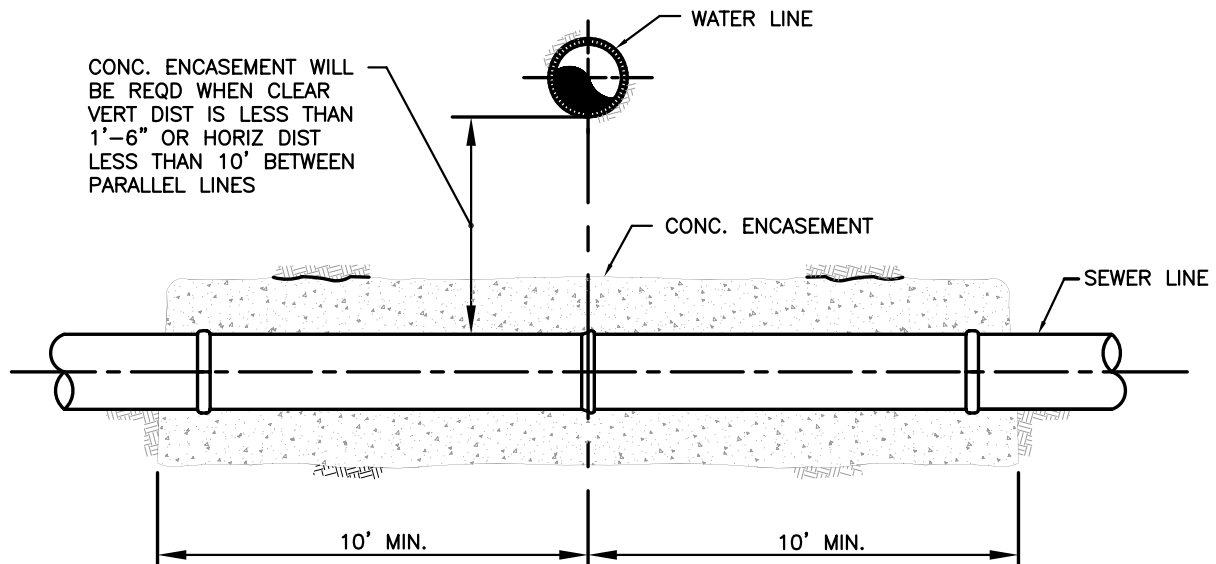

NOTE:

1. Concrete Encasement Required In All Cases Where Sewer Lines Is Above Water Line.
2. Minimum Width and Depth are 12" + Pipe O.D.
3. Install Rebar per Detail #13.

Detail Number:

14

REVISED: 4/2010

ST. VRAIN SANITATION DISTRICT MONITORING MANHOLE

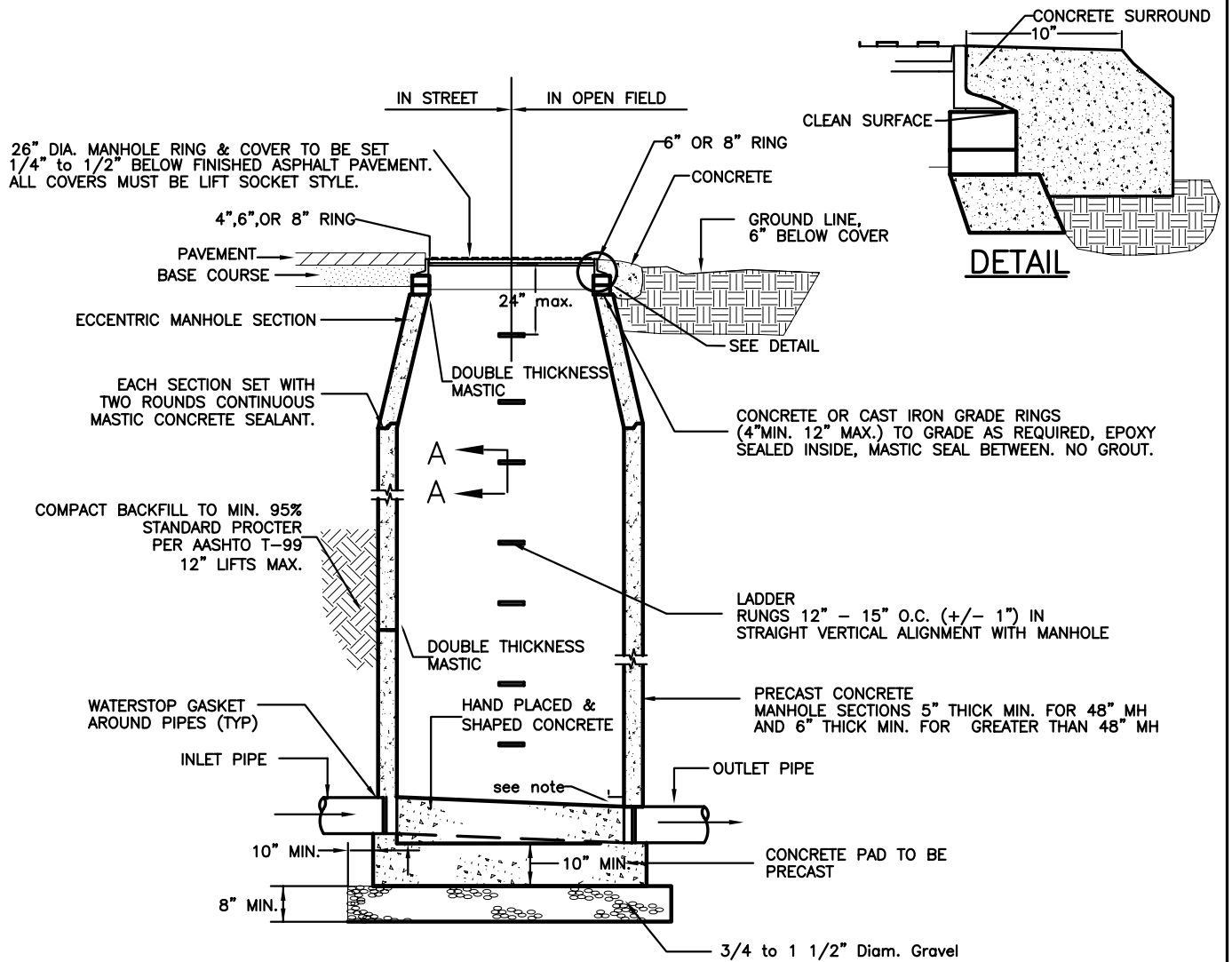

NOTE:

1. MANHOLES SHALL BE SEALED WATERTIGHT. NO GROUT ALLOWED EXCEPT AT PIPE PENETRATIONS. MANHOLE EXTERIORS SHALL BE DAMP-PROOFED.
2. DROP THROUGH MANHOLE TO BE EQUAL TO SLOPE OF SURROUNDING PIPE. FOR FLUME INSTALLATIONS, FLUME MUST BE SET LEVEL.
3. MONITORING MANHOLE TO BE LOCATED OUTSIDE OF PUBLIC RIGHT-OF-WAY, ON DISCHARGER'S PROPERTY. THE MANHOLE MUST BE SAFELY AND INDEPENDENTLY ACCESSIBLE FOR DISTRICT USE AT ALL TIMES.
4. FOR MANHOLE DEPTHS LESS THAN FOUR (4) FEET FROM RIM TO TOP OF BENCH, VERTICAL MANHOLE BARRELS OR MINIMUM 30-INCH BY 30-INCH PRECAST BOX WITH PRECAST FLAT TOP SECTIONS ARE REQUIRED.
5. DESIGN AND LOCATION OF MONITORING MANHOLE SUBJECT TO DISTRICT APPROVAL.

Detail Number:

15

REVISED: 4/2010

ST. VRAIN SANITATION DISTRICT MONITORING MANHOLE DETAIL TOP VIEW DIAGRAMS

CORRECT INSTALLATION

NO SCALE/PICTORIAL ONLY

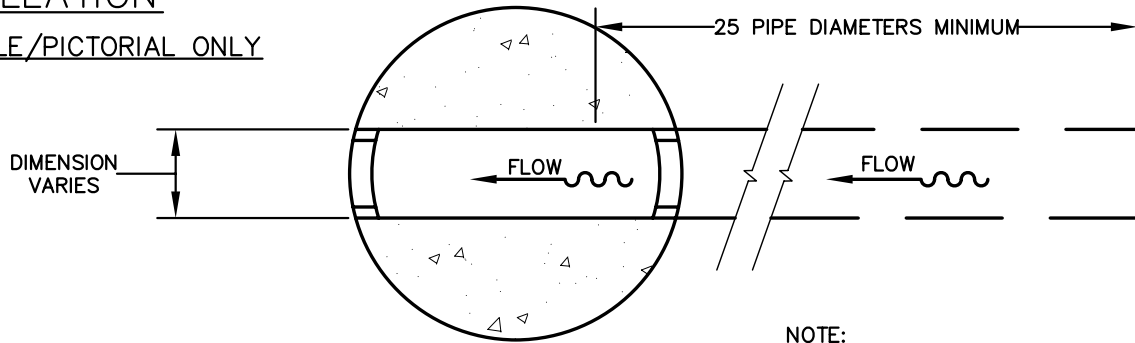
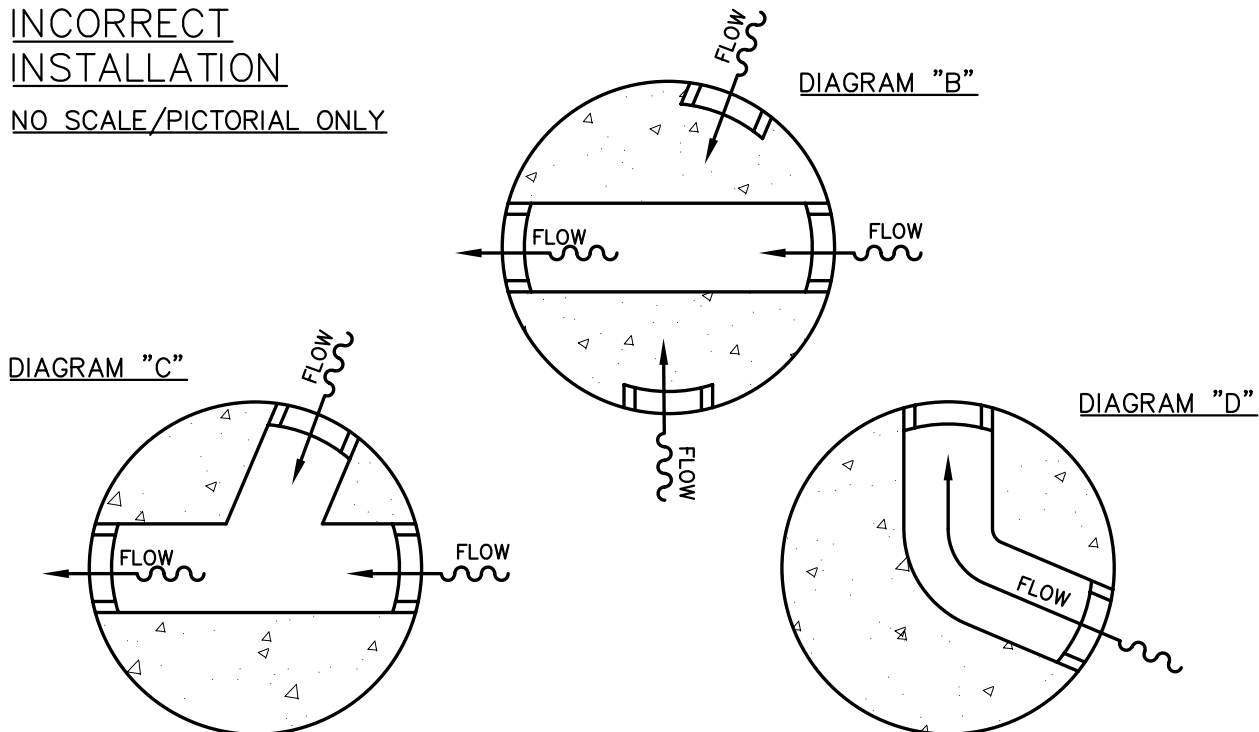

DIAGRAM "A"

NOTE:
THERE SHALL NOT BE ANY
BENDS, DROP MANHOLE FLOW
JUNCTIONS, ETC., WITHIN 25
PIPE DIAMETERS UPSTREAM OR
DOWNSTREAM OF THE MANHOLE

INCORRECT INSTALLATION

NO SCALE/PICTORIAL ONLY



NOTES:

DIAGRAM "A" IS COMPATIBLE FOR THE INSTALLATION OF A FLOWMETER OR FLUME IN THE INVERT.

DIAGRAMS "B", "C", "D" ARE NOT SUITABLE FOR THE INSTALLATION OF A FLOW MEASURING DEVICE DUE TO THE LOCATION OF THE SIDE SEWERS OR A BEND IN THE INVERT CHANNEL.

Detail Number:

16

REVISED: 4/2010

ST. VRAIN SANITATION DISTRICT EXAMPLE SITE PLAN

COMPANY NAME
ADDRESS
CITY, STATE ZIP CODE

NOTES:

- 1) INDICATE A NUMBER FOR EACH MONITORING MANHOLE.
- 2) INDICATE SEWER SIZES (DIAMETERS).
- 3) INDICATE LOCATION OF SEWAGE FLOW METER, IF REQUIRED.
- 4) DETAIL OF MONITORING MANHOLE MUST BE SUBMITTED ON SEPARATE SHEET.

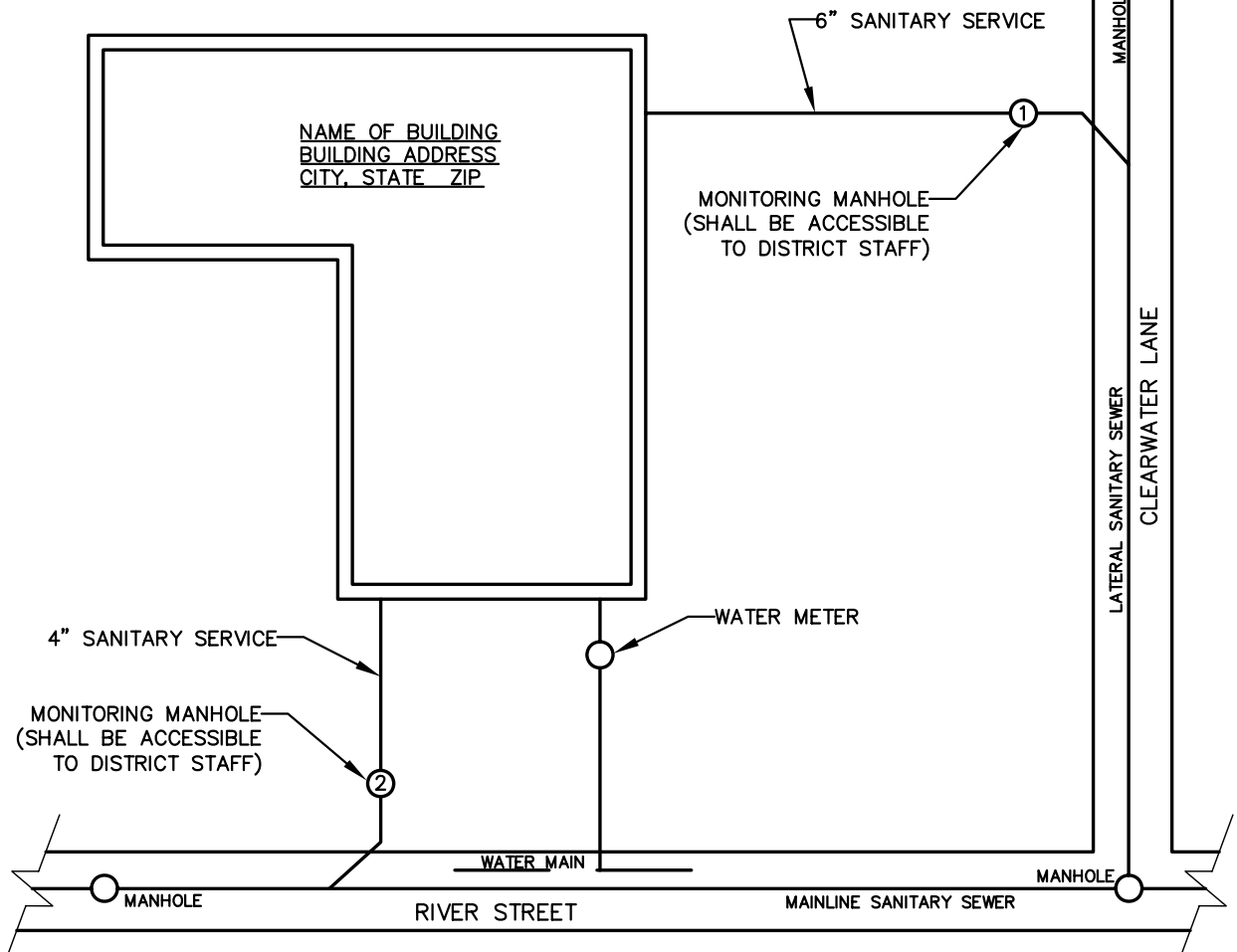
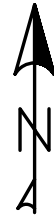

Detail Number:

17

REVISED: 4/2010

ST. VRAIN SANITATION DISTRICT STANDARD PIPE CASING DETAIL

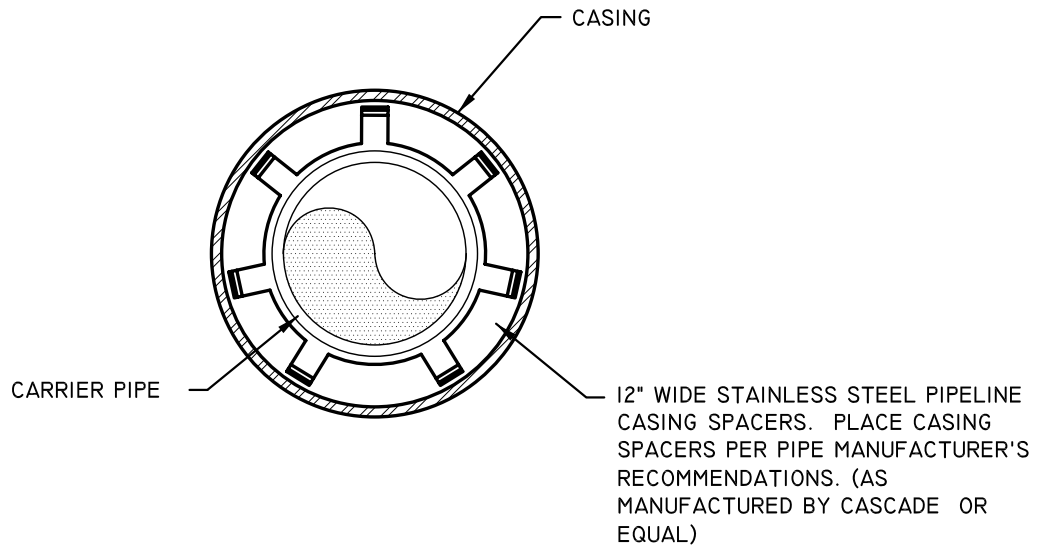

SEAL END OF CASING PIPE WITH FABRICATED BUTYL RUBBER SEAL $\frac{1}{8}$ " THICK, WITH STAINLESS STEEL BANDS $\frac{3}{4}$ " WIDE-10 GA.

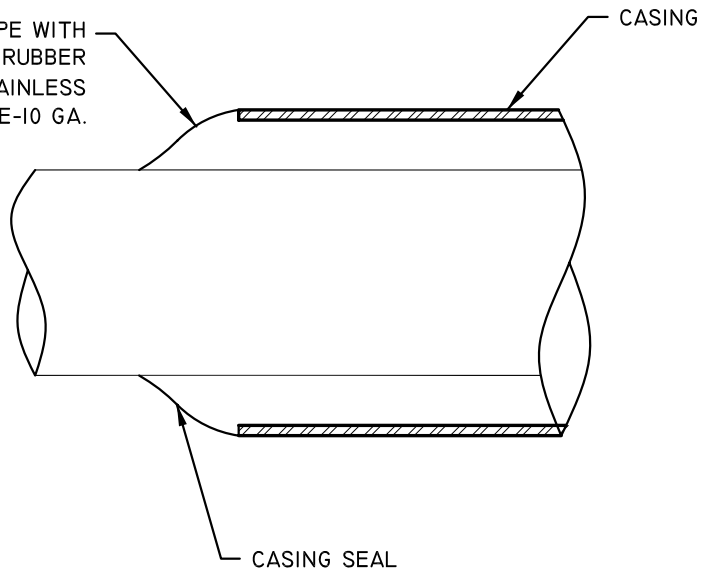

Detail Number:

18

REVISED: 4/2010

ST. VRAIN SANITATION DISTRICT CUT-OFF WALL DETAIL

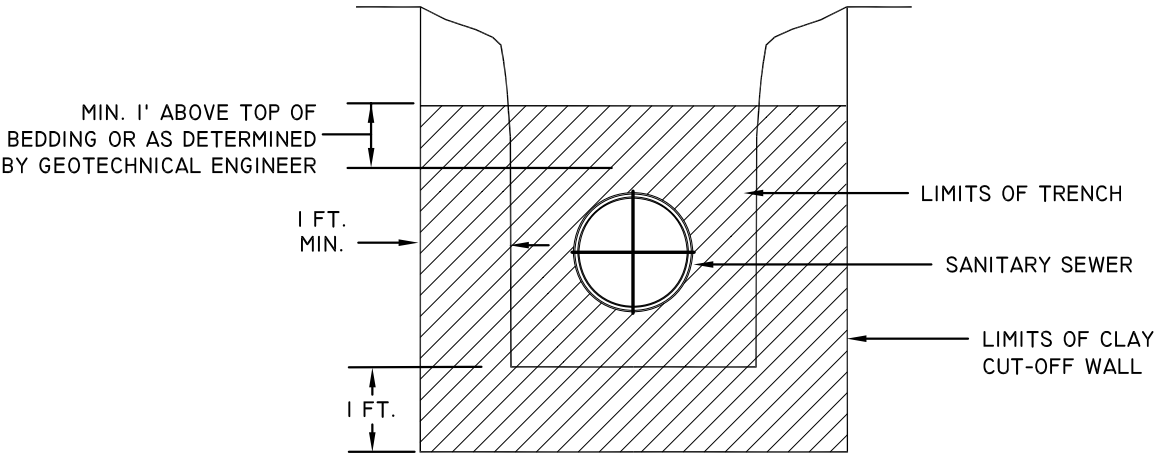
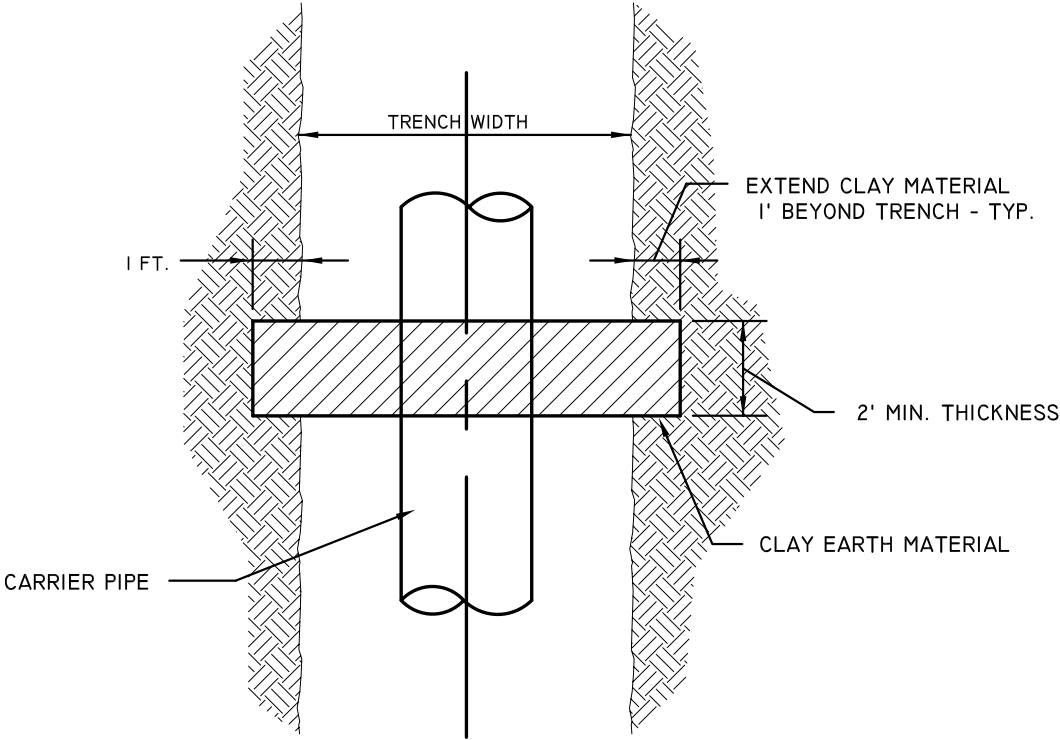

- NOTES:**
1. CLAY WALL EXTENDS A MINIMUM OF 12 INCHES INTO UNDISTURBED SOIL ON EACH SIDE AND ON BOTTOM OF TRENCH.
 2. CLAY MATERIAL TO BE CLASSIFIED AS CL, CH OR OH.
 3. FLOWFILL MAY BE USED INSTEAD OF CLAY MATERIAL.

Detail Number:

19

REVISED: 4/2010

ST. VRAIN SANITATION DISTRICT PIPE PRESSURE TEST PARAMETERS

MINIMUM SPECIFIED TIME REQUIRED FOR A 0.5 PSIG PRESSURE DROP
FOR SIZE AND LENGTH OF PIPE INDICATED FOR Q = 0.0015

| 1 PIPE DIAMETER (IN.) | 2 MINIMUM TIME (MIN:SEC) | 3 LENGTH FOR MINIMUM TIME (FT) | 4 TIME FOR LONGER LENGTH (SEC) | SPECIFICATIONS TIME FOR LENGTH (L) SHOWN (MIN:SEC) | | | | | | | | | | |
|--------------------------------|-----------------------------------|---|---|--|--------|--------|--------|--------|--------|--------|--------|--------|--------|--------|
| | | | | 100 FT | 150 FT | 200 FT | 250 FT | 300 FT | 350 FT | 400 FT | 450 FT | | | |
| 4 | 1:53 | 597 | 0.190 L | 1:53 | 1:53 | 1:53 | 1:53 | 1:53 | 1:53 | 1:53 | 1:53 | 1:53 | 1:53 | 1:53 |
| 6 | 2:50 | 398 | 0.427 L | 2:50 | 2:50 | 2:50 | 2:50 | 2:50 | 2:50 | 2:50 | 2:50 | 2:50 | 2:50 | 2:50 |
| 8 | 3:47 | 298 | 0.760 L | 3:47 | 3:47 | 3:47 | 3:47 | 3:47 | 3:47 | 3:47 | 3:47 | 3:47 | 3:47 | 3:47 |
| 10 | 4:43 | 239 | 1.187 L | 4:43 | 4:43 | 4:43 | 4:43 | 4:43 | 4:43 | 4:43 | 4:43 | 4:43 | 4:43 | 4:43 |
| 12 | 5:40 | 199 | 1.709 L | 5:40 | 5:40 | 5:40 | 5:40 | 5:40 | 5:40 | 5:40 | 5:40 | 5:40 | 5:40 | 5:40 |
| 15 | 7:05 | 159 | 2.671 L | 7:05 | 7:05 | 8:54 | 11:08 | 13:21 | 15:35 | 17:48 | 19:51 | 22:04 | 24:17 | 26:30 |
| 18 | 8:30 | 133 | 3.846 L | 8:30 | 9:37 | 12:49 | 16:01 | 19:14 | 22:26 | 25:38 | 28:51 | 32:03 | 35:15 | 38:27 |
| 21 | 9:55 | 114 | 5.235 L | 9:55 | 13:05 | 17:27 | 21:49 | 26:11 | 30:32 | 34:54 | 39:16 | 43:37 | 47:59 | 52:21 |
| 24 | 11:20 | 99 | 6.837 L | 11:24 | 17:57 | 22:48 | 28:30 | 34:11 | 39:53 | 45:35 | 51:17 | 56:58 | 62:40 | 68:21 |
| 27 | 12:45 | 88 | 8.653 L | 14:25 | 21:38 | 28:51 | 36:04 | 43:16 | 50:30 | 57:42 | 64:54 | 72:07 | 79:19 | 86:31 |
| 30 | 14:10 | 80 | 10.683 L | 17:48 | 26:43 | 35:37 | 44:31 | 53:25 | 62:19 | 71:13 | 80:07 | 88:51 | 97:45 | 106:39 |
| 33 | 15:35 | 72 | 12.926 L | 21:33 | 32:19 | 43:56 | 53:52 | 64:38 | 75:24 | 86:10 | 96:57 | 107:43 | 118:29 | 129:15 |
| 36 | 17:00 | 66 | 15.384 L | 25:39 | 38:28 | 51:17 | 64:06 | 76:55 | 89:44 | 102:34 | 115:23 | 128:12 | 141:01 | 153:50 |
| 42 | 19:54 | 57 | 20.942 L | 34:54 | 52:21 | 69:49 | 87:15 | 104:42 | 122:10 | 139:37 | 157:04 | 174:31 | 191:58 | 209:25 |
| 48 | 22:47 | 50 | 27.352 L | 45:35 | 68:23 | 91:11 | 113:58 | 136:46 | 159:33 | 182:21 | 205:09 | 227:56 | 250:44 | 273:32 |
| 54 | 25:31 | 44 | 34.618 L | 57:42 | 86:33 | 115:24 | 144:15 | 173:05 | 201:56 | 230:47 | 259:38 | 288:29 | 317:20 | 346:11 |
| 60 | 28:20 | 40 | 42.738 L | 71:14 | 106:51 | 142:28 | 178:05 | 213:41 | 249:18 | 284:55 | 320:32 | 356:09 | 391:46 | 427:23 |

NOTE: IF THERE HAS BEEN NO LEAKAGE (ZERO PSIG DROP) AFTER ONE HOUR OF TESTING, THE TEST SECTION SHALL BE ACCEPTED AND THE TEST SHALL BE COMPLETE.

Detail Number:
20

REVISED: 4/2010

ST. VRAIN SANITATION DISTRICT

CONCRETE AGGREGATE GRADATION TABLE, PERCENTAGES PASSING DESIGNATED SIEVES AND NOMINAL SIZE DESIGNATION

| Sieve Size | Coarse Aggregates (From AASHTO M 43) | | | | | | | | | | | Fine Aggregate |
|------------------|--------------------------------------|-------------------------------------|----------------------------------|---------------------------------|--------------------------------|-------------------------------|---------------------------------|-------------------------------|-----------------------------------|--------------------------------|--|----------------|
| | No. 3 | No. 4 | No. 6 | No. 7 | No. 8 | No. 57 | No. 67 | No. 357 | No. 467 | AASHTO M6 | | |
| | 50 mm to 25.0 mm (2" to 1") | 37.5 mm to 19.0 mm (1 1/2" to 3/4") | 19.5 mm to 9.5 mm (3/4" to 3/8") | 12.5 mm to 4.75 mm (1/2" to #4) | 9.5 mm to 2.36 mm (3/8" to #8) | 25.0 mm to 4.75 mm (1" to #4) | 19.0 mm to 4.75 mm (3/4" to #4) | 50.0 mm to 4.75 mm (2" to #4) | 37.5 mm to 4.75 mm (1 1/2" to #4) | 4.75 mm to 150 μm (#4 to #100) | | |
| 63.0 mm (2 1/2") | 100 | | | | | | | 100 | | | | |
| 50.0 mm (2") | 90-100 | 100 | | | | | | 95-100 | 100 | | | |
| 37.5 mm (1 1/2") | 35-70 | 90-100 | | | | 100 | | 95-100 | 95-100 | | | |
| 25.0 mm (1") | 0-15 | 20-55 | 100 | | | 95-100 | 100 | 35-70 | | | | |
| 19.0 mm (3/4") | | 0-15 | 90-100 | 100 | | | 90-100 | | 35-70 | | | |
| 12.5 mm (1/2") | 0-5 | | 20-55 | 90-100 | 100 | 25-60 | | 10-30 | | | | |
| 9.5 mm (3/8") | | 0-5 | 0-15 | 40-70 | 85-100 | | 20-55 | | 10-30 | 100 | | |
| 4.75 mm (#4) | | | 0-5 | 0-15 | 10-30 | 0-10 | 0-10 | 0-5 | | 95-100 | | |
| 2.36 mm (#8) | | | | 0-5 | 0-10 | 0-5 | 0-5 | | 0-5 | | | |
| 1.18 mm (#16) | | | | | | | | | | 45-80 | | |
| 300 μm (#50) | | | | | | | | | | 10-30 | | |
| 150 μm (#100) | | | | | | | | | | 2-10 | | |

Detail Number:

21

REVISED: 4/2010

ST. VRAIN SANITATION DISTRICT TYPICAL GREASE INTERCEPTOR

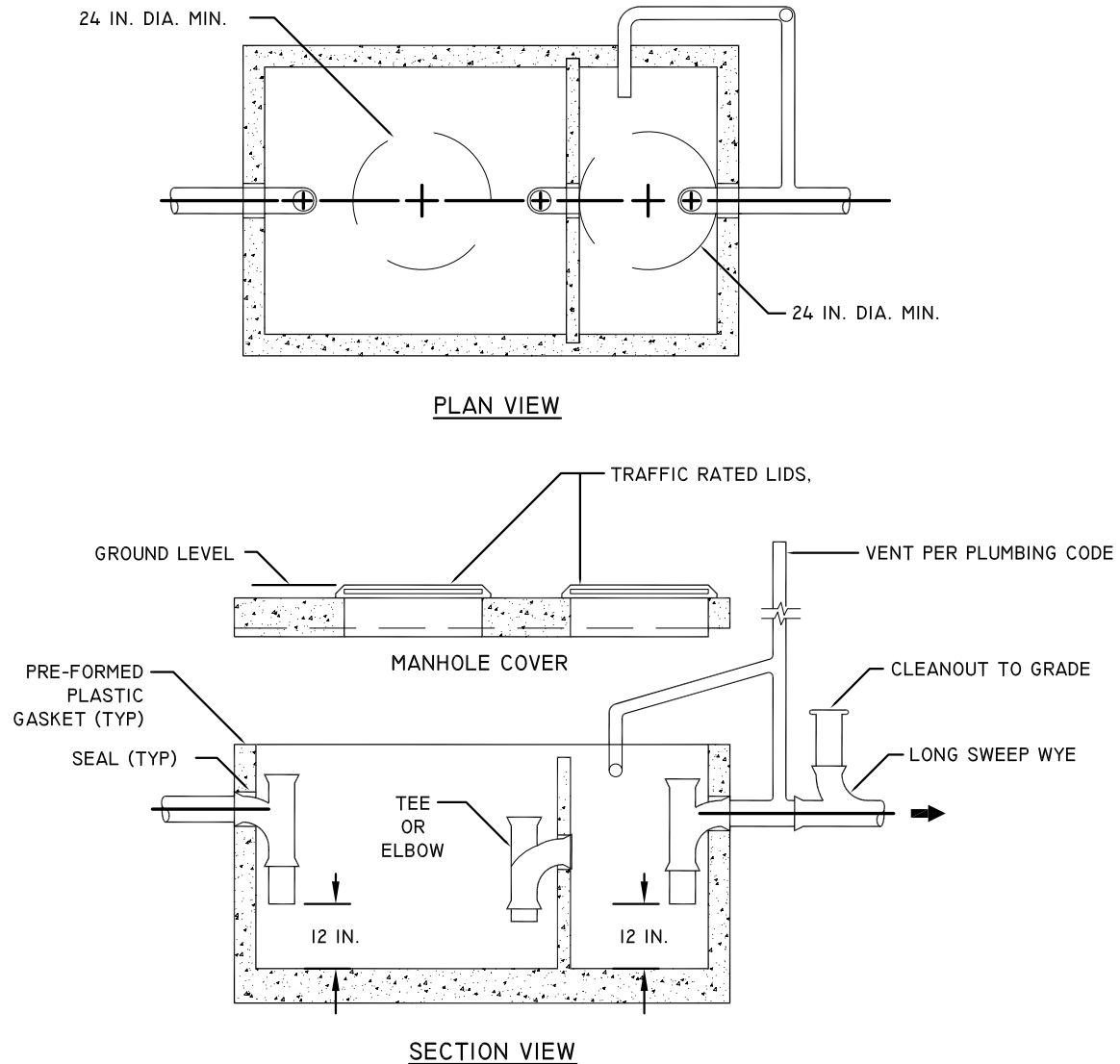

NOTES:

1. SECONDARY OUTLET COMPARTMENT HAS VOLUME EQUAL TO 1/3 OF TOTAL CAPACITY.
2. CHECK WITH SUPPLIER FOR EXACT DIMENSIONS.
3. INTERCEPTORS TO BE SIZED BY DESIGN ENGINEER, SUBJECT TO DISTRICT APPROVAL.
4. GREASE INTERCEPTORS SHALL BE LOCATED ON PRIVATE PROPERTY AND SHALL BE EASILY ACCESSIBLE AT ALL TIMES, FOR MAINTENANCE AND INSPECTION.
5. INLET AND OUTLET SHALL HAVE SANITARY TEES; CENTER BAFFLE MAY HAVE TEE OR ELBOW.

Detail Number:

22

REVISED: 4/2010

ST. VRAIN SANITATION DISTRICT CLEANOUT (LAMPHOLE) COVER ASSEMBLY FOR CLEANOUTS 6" AND LARGER

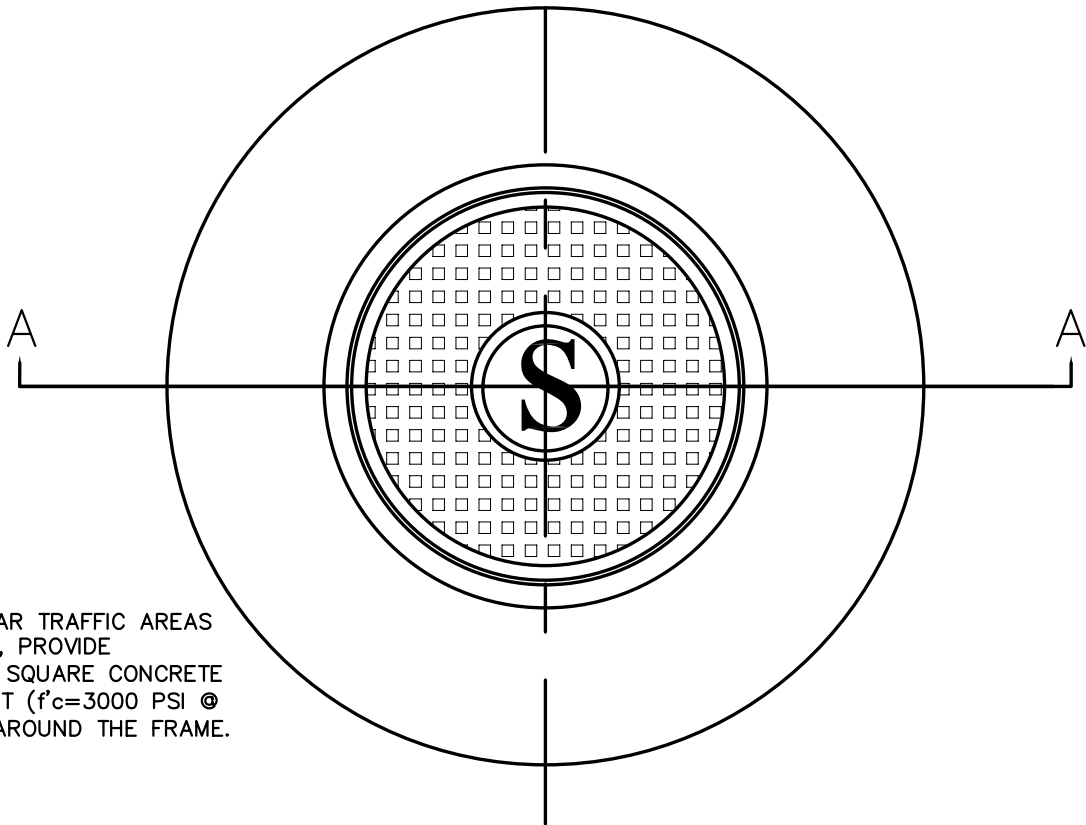

NOTE:
IN VEHICULAR TRAFFIC AREAS
NOT PAVED, PROVIDE
2'x2'x8"(H) SQUARE CONCRETE
ENCASEMENT ($f'_c=3000$ PSI @
28 DAYS) AROUND THE FRAME.

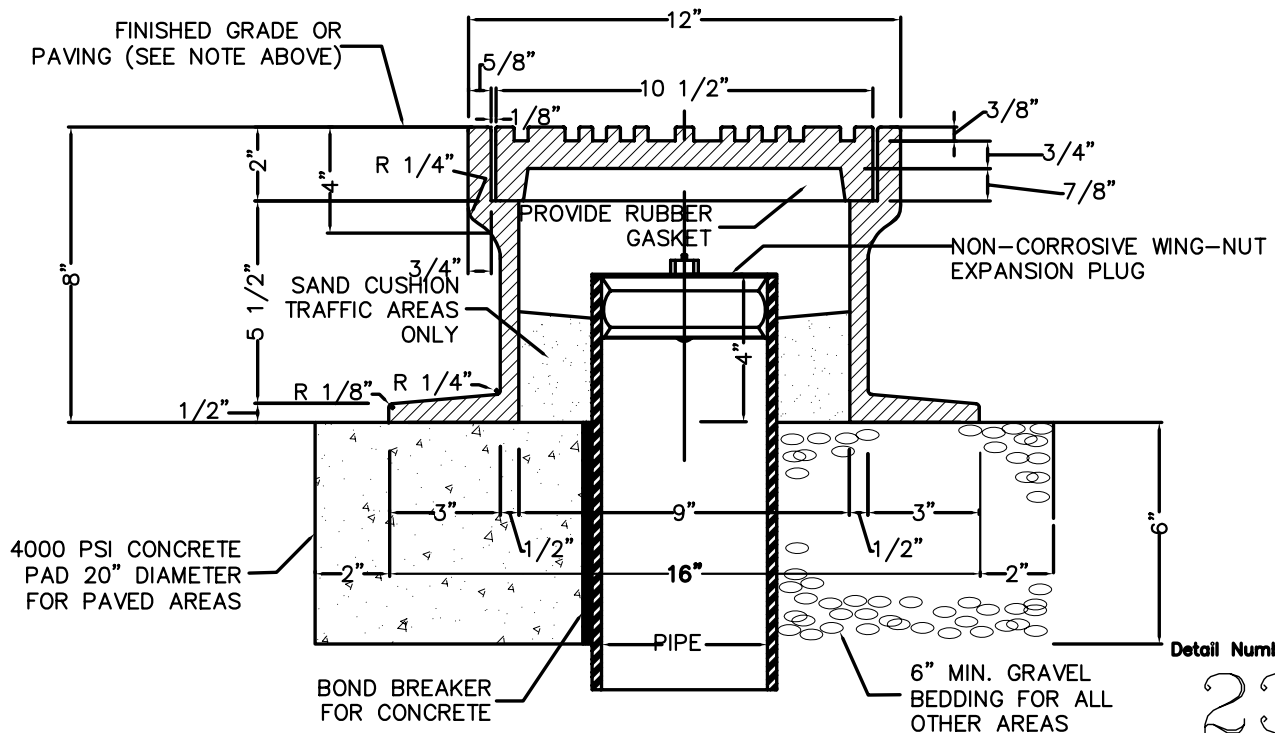

SECTION A-A

Detail Number:

23

REVISED: 4/2010

ST. VRAIN SANITATION DISTRICT APPENDIX B GENERAL CONSTRUCTION NOTES
REVISED 4/2010

1. District shall refer to the St. Vrain Sanitation District in these notes.
2. District's acceptance of these plans is valid for one year.
3. All materials and construction shall conform to the District standards.
4. Contractor to verify locations and elevations of existing utilities prior to commencing any construction.
5. The contractor shall notify the District a minimum of 48 hours and a maximum of 96 hours prior to starting construction or prior to resuming construction after a break.
6. Sanitary sewer shall be polyvinyl chloride (PVC) pipe, ASTM D3034-SDR35 (or as indicated on the plans).
7. All concrete shall be minimum 4000 psi at 28 day strength.
8. Maintain a minimum of 10 feet horizontal separation outside diameter to outside diameter between water lines and all sewer lines and manholes.
9. All sewer mains crossing water mains with less than 18 inches of separation shall be encased in concrete.
10. Rim elevations shown are approximate and should not be taken as final. All manholes shall be final adjusted after paving such that the rim is $\frac{1}{4}$ to $\frac{1}{2}$ inch below finished asphalt. Manholes in unpaved areas shall be set so that the rim is 0.5' above finished grade.
11. The contractor shall have a set of approved plans on site at all times. The contractor shall be responsible for recording actual record drawing dimensions and distances as well as service locations on these plans and submitting them to the engineer for preparation of record drawings. These drawings shall be kept current at all times.
12. Before any construction commences, a plug shall be installed to prevent drainage through the new sewer line from entering the existing sewer line. This plug will be installed in the manhole, which connects new work with the existing and not be removed until initial acceptance.
13. Underdrains, if installed, are the responsibility of the developer. District assumes no liability for any portion of or any damage caused by underdrains. Absolutely no part of an underdrain system, including clean outs, will be allowed inside of sanitary sewer manholes. All underdrains shall be installed below the sanitary sewer and offset to the side. Pipe material shall be different color than sanitary sewer.
14. No service laterals smaller than 8 inch in diameter shall enter manholes.
15. Service crossings of curb shall be marked with a cut "S" in curb face. Paint is not acceptable. Service shall be extended into the lot a minimum of 10 feet.
16. Contractor shall mark the end of all sewer services with a 2" x 4" board with minimum of four (4) feet above grade, painted green.
17. All pipes shall have squeegee (CDOT #8 bedding) unless otherwise shown or the District may approve an alternate bedding in special cases.
18. Cut off walls will be installed 10' down stream of each manhole on the main outfall line.
19. The warranty bond shall be in the amount of \$5,000.00 or 15% of the total cost of the sewer, whichever is greater.
20. Prior to approval, all sanitary sewer pipes shall be pressure-tested per ASTM C924. All manholes shall be vacuum-tested per UNI-B-98.
21. Prior to removal of plugs at manholes, pipe shall be jet-cleaned and vacuumed to remove debris and videoed. Notice shall be given to the District Inspector one (1) week prior to cleaning. Inspector must be present during the operation. Once approval has been given by Inspector, plugs may be only be removed after initial acceptance by the District.
22. The final recorded plat and recorded address plat shall be provided to the District for initial acceptance.
23. Twenty (20) months after construction and prior to the expiration of warranty, the developer shall camera/video the sanitary sewer lines and provide a DVD to the District for review.